

Ikarus Ik-2

Country: Yugoslavia

Service Entry Date: 1937

A/C Type: Day Fighter
 Engine(s): Hispano-Suiza 12 Ycrs V-12
 Eng. Pwr: 860-hp, Liquid-cooled, Non-F.I.
 A/C Crew: Pilot

Maximum Speed: 266 mph @ 16,400 ft
 Maximum Ceiling: 34,450 ft
 Defense factor: 5 Size Modifier: 0
 Damage Factor: 5/8 Endurance: 168
 Cockpit View: Poor Blind Area: Rear
 Protection: Engine +0 Fuel +0 Cockpit +0
 Climb Dece/ Dive Accel: 3.0 / 1.0
 Weight and Load Limit: none
 Wpn Stations Weight Allowed Loads

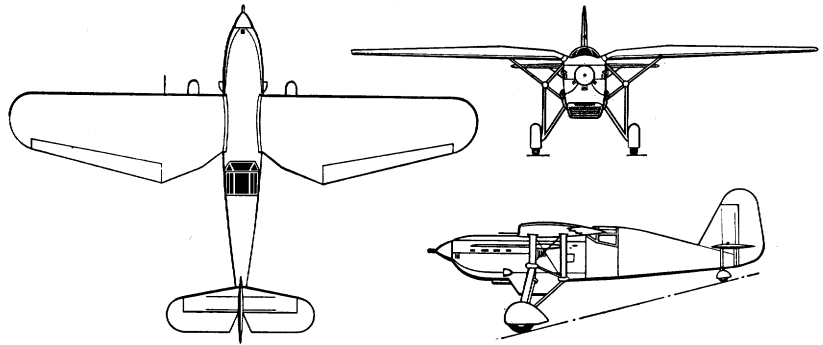

Class: F

Victory Points: 3-5

AIRCRAFT PERFORMANCE CHART

Altitude Levels	Bands	Minimum Speed	Maximum Speed	Maximum Dive Spd	Min TT(2)	Min HT(3)	Min BT(3)	Min ET(4)	Altitude Levels	Bands	Average Rate of Climb
43+	UH	--	--	--	--	--	--	--	43+	UH	--
37-42	EH	--	--	--	--	--	--	--	37-42	EH	--
31-36	VH	2.5	4.0	7.5	4.0	5.5	6.5	7.5	31-36	VH	800
25-30	HI	2.0	4.0	8.0	3.5	5.0	6.0	7.0	25-30	HI	1,200
19-24	MH	2.0	5.0	8.5	3.0	4.5	5.5	6.5	19-24	MH	2,000
13-18	ML	1.5	5.5	8.5	2.5	4.0	5.0	6.0	13-18	ML	2,700
7-12	LO	1.5	5.0	7.5	2.0	3.5	4.5	5.5	7-12	LO	3,000
1-6	VL	1.5	4.0	6.5	2.0	3.0	4.0	5.0	1-6	VL	3,200

FIRE POWER CHART

Guns	Type Weapons	Ammo	Criticals
N1	1x HS-404 20mm cannon	3	2
W1	1x 7.92 Darne MG	8	4
W2	1x 7.92 Darne MG	8	4

GUN ATTACK FACTORS

Range	N1	W1	W2	Total
0	22	5	5	32
1	16	3	3	22
2	11	2	2	15
3	7	1	1	9
4	5	1	1	7
5	4	1	1	6
6	3	--	--	3
7	--	--	--	

WEAPON STATION LOCATION

POWER VERSUS SPEED CHART

Levels	Bands	1.0 - 4.5	5.0 - 7.5	8.0 - 9.5	10.0+	Band
43+	UH	--	--	--	--	UH
37-42	EH	--	--	--	--	EH
31-36	VH	1	--	--	--	VH
25-30	HI	2	--	--	--	HI
19-24	MH	4	1	--	--	MH
13-18	ML	6	3	--	--	ML
7-12	LO	7	4	--	--	LO
1-6	VL	7	--	--	--	VL
Banking FPs		3	4	5	--	
Side Slip FPs		4	5	7	9	

NOTES AND VARIANTS

Ikarus Ik-2: All-metal high wing monoplane fighter designed by Yugoslav engineers in 1935. 12 built and delivered 1936-1937. 8 still in service in April 1941, serving with 34th squadron of 4th Fighter Regiment, alongside 6 Hurricanes. Used strafe advancing German columns. Survivors were absorbed by the Croatian Air Force. Fixed gear.

Rogozarski Ik-3

A/C Type: Day Fighter
 Engine(s): Avia-built Hispano-Suiza 12 Ycrs
 Eng. Pwr: 920-hp, Liquid-cooled, Non-F.I.
 A/C Crew: Pilot

Maximum Speed: 327 mph @ 17,700 ft
 Maximum Ceiling: 26,250 ft
 Defense factor: 5 Size Modifier: 0
 Damage Factor: 7/11 Endurance: 76
 Cockpit View: Fair Blind Area: Rear
 Protection: Engine +1 Fuel +0 Cockpit +0
 Climb Dece/ Dive Accel: 3.0 / 1.0
 Weight and Load Limit: none
 Wpn Stations Weight Allowed Loads

Country: Yugoslavia

Service Entry Date: March 1940

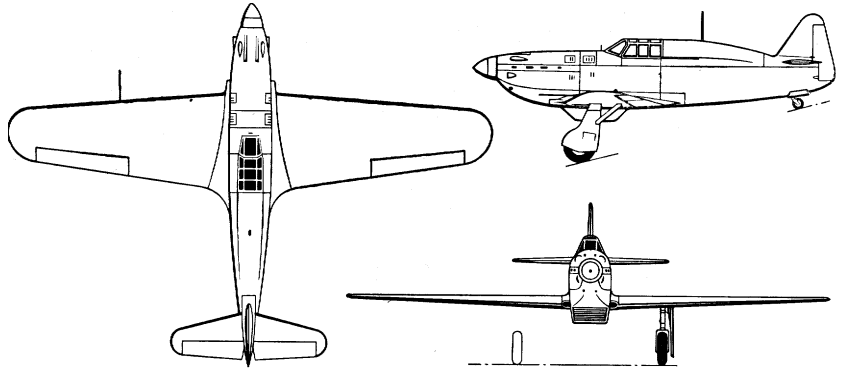

Class: F

Victory Points: 4-6

AIRCRAFT PERFORMANCE CHART

Altitude Levels	Bands	Minimum Speed	Maximum Speed	Maximum Dive Spd	Min TT(2)	Min HT(3)	Min BT(4)	Min ET(5)	Altitude Levels	Bands	Average Rate of Climb
43+	UH	--	--	--	--	--	--	--	43+	UH	--
37-42	EH	--	--	--	--	--	--	--	37-42	EH	--
31-36	VH	--	--	--	--	--	--	--	31-36	VH	--
25-30	HI	3.0	5.5	9.5	3.5	4.5	5.5	6.5	25-30	HI	600
19-24	MH	2.5	6.0	10.0	3.0	4.0	5.0	6.0	19-24	MH	1,200
13-18	ML	2.5	6.5	10.0	2.5	3.5	4.5	6.0	13-18	ML	2100
7-12	LO	2.0	6.5	9.5	2.0	3.0	4.0	5.5	7-12	LO	2400
1-6	VL	2.0	6.0	8.5	2.0	3.0	4.0	5.0	1-6	VL	2700

FIRE POWER CHART

Guns	Type Weapons	Ammo	Criticals
N1	1x HS-4 20mm cannon	3	2
N2	2x 7.92 FN-Browning MG	12	4

GUN ATTACK FACTORS

Range	N1	N2	Total
0	22	11	33
1	16	8	24
2	11	6	17
3	7	4	11
4	5	2	7
5	4	1	5
6	3	--	3
7	--	--	--

WEAPON STATION LOCATION

POWER VERSUS SPEED CHART

Levels	Bands	1.0 - 4.5	5.0 - 7.5	8.0 - 9.5	10.0+	Band
43+	UH	--	--	--	--	UH
37-42	EH	--	--	--	--	EH
31-36	VH	--	--	--	--	VH
25-30	HI	2	1	--	--	HI
19-24	MH	4	2	--	--	MH
13-18	ML	7	4	--	--	ML
7-12	LO	7	4	--	--	LO
1-6	VL	7	4	--	--	VL
Banking FPs		2	3	4	5	
Side Slip FPs		3	4	6	7	

NOTES AND VARIANTS

Ikarus-3: Yugoslav-designed and built, this was a well-respected aircraft, supposedly better than the Bf109E series and outturned a Hurricane I. However, only 12 built in the Spring of 1941 (though an order for 25 more was just started):

- 4 were undergoing overhaul and were destroyed to prevent capture;
- 1 was being fitted with a RR Merlin III engine (which worked well) as part of a program to replace the French Hispano Suiza engine;
- 1 was destroyed by pilot error shortly before the invasion.

The remaining 6 served with the 52nd Squadron; together with 10 Bf109E-3s of the 32nd Squadron, they formed the 6th Fighter Regiment defending Belgrade. They shot down 10 German aircraft; all were destroyed in combat.

IAR-80

A/C Type: Day Fighter
 Engine(s): Gnome-Rhone 14K Mistral-Major
 Eng. Pwr: 940-hp, Air-cooled, Non-F.I.
 A/C Crew: Pilot

Maximum Speed: 317 mph @ 13,000 ft
 Maximum Ceiling: 34,500 ft
 Defense factor: 5 Size Modifier: 0
 Damage Factor: 7/11 Endurance: 171
 Cockpit View: Fair Blind Area: Rear
 Protection: Engine +1 Fuel +0 Cockpit +0
 Climb Dece/ Dive Accel: 3.0 / 1.0
 Weight and Load Limit: 880 (1320)/3-4 (5)
 Wpn Stations Weight Allowed Loads
 1,2,4,5 220 lbs 50 or 100kg bomb
 3 (IAR-81 only) 440 lbs 1x 200 kg bomb

Country: Rumania

Service Entry Date: February 1942

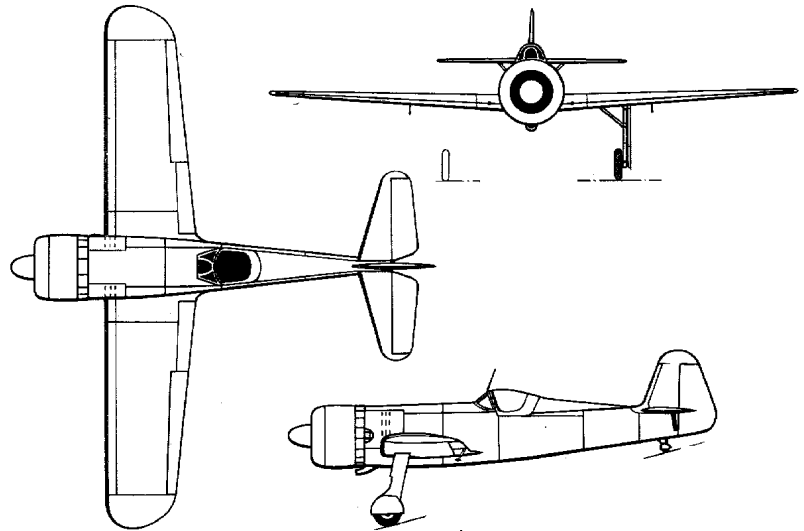

Class: F

Victory Points: 4-6

AIRCRAFT PERFORMANCE CHART

Altitude Levels	Bands	Minimum Speed	Maximum Speed	Maximum Dive Spd	Min TT(2)	Min HT(3)	Min BT(4)	Min ET(5)	Altitude Levels	Bands	Average Rate of Climb
43+	UH	--	--	--	--	--	--	--	43+	UH	--
37-42	EH	--	--	--	--	--	--	--	37-42	EH	--
31-36	VH	2.5	5.0	9.5	4.5	6.0	7.0	8.0xfp	31-36	VH	300
25-30	HI	2.0	5.5	9.5	4.0	5.5	6.5	7.5	25-30	HI	1000
19-24	MH	2.0	6.0	9.5	3.5	5.0	6.0	7.0	19-24	MH	1600
13-18	ML	1.5	6.5	10.0	3.0	4.5	5.5	6.5	13-18	ML	2100
7-12	LO	1.5	6.0	9.0	3.0	4.0	5.0	6.0	7-12	LO	2400
1-6	VL	1.5	5.5	8.0	2.5	3.0	4.0	5.0	1-6	VL	2700

FIRE POWER CHART

Guns	Type Weapons	Ammo	Criticals
W1	1x 20mm MG-151/20	3	2
W2	2x 7.7mm MG	12	4
W3	2x 7.7mm MG	12	4
W4	1x 20mm MG-151/20	3	2

GUN ATTACK FACTORS

Range	N1	N2	N3	N4	Total
0	26	12	12	26	76
1	20	8	8	20	56
2	13	6	6	13	38
3	9	4	4	9	26
4	6	3	3	6	18
5	4	2	2	4	12
6	3	--	--	3	6
7	--	--	--	--	--

WEAPON STATION LOCATION



1 2 3 4 5

POWER VERSUS SPEED CHART

Levels	Bands	1.0 - 4.5	5.0 - 7.5	8.0 - 9.5	10.0+	Band
43+	UH	--	--	--	--	UH
37-42	EH	--	--	--	--	EH
31-36	VH	2	1	--	--	VH
25-30	HI	3	1	--	--	HI
19-24	MH	4	2	--	--	MH
13-18	ML	7	4	--	--	ML
7-12	LO	8	5	--	--	LO
1-6	VL	8	5	--	--	VL
Banking FPs		2	3	5	7	
Side Slip FPs		3	4	6	9	

NOTES AND VARIANTS

IAR-80: Developed using fuselage and engine elements of the PZL P-24E (which was being produced by I.A.R. under license 1938-41), this low-wing monoplane fighter was Rumania's only indigenous design. Produced 1941-43 (when factory changed over to Bf109G production). No station 3. These served in Russia; 120 in Rumanian home defense units in early 1944.

IAR-81: Available October 1942. A few fighter-bomber versions of the IAR 80 were produced. This included a fuselage station for a heavy(200 kg) bomb.

Avia B.534.IV

A/C Type: Day Fighter
 Engine(s): Avia-built Hispano-Suiza 12 Ydrs
 Eng. Pwr: 850-hp, Liquid-cooled, Non-F.I.
 A/C Crew: Pilot

Maximum Speed: 245 mph @ 14,435 ft
 Maximum Ceiling: 34,600 ft
 Defense factor: 5 Size Modifier: 0
 Damage Factor: 7/10 Endurance: 96
 Cockpit View: Fair Blind Area: Rear
 Protection: Engine +1 Fuel +0 Cockpit +0
 Climb Dece/ Dive Accel: 3.0 / 1.0
 Weight and Load Limit: none
 Wpn Stations Weight Allowed Loads

Country: Czechoslovakia

Service Entry Date: May 1937

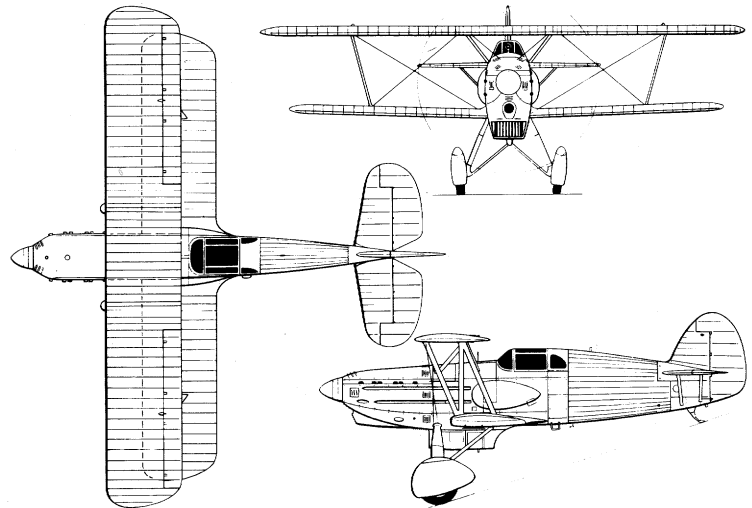

Class: F

Victory Points: 3-6

AIRCRAFT PERFORMANCE CHART

Altitude Levels	Bands	Minimum Speed	Maximum Speed	Maximum Dive Spd	Min TT(1)	Min HT(2)	Min BT(3)	Min ET(4)	Altitude Levels	Bands	Average Rate of Climb
43+	UH	--	--	--	--	--	--	--	43+	UH	--
37-42	EH	--	--	--	--	--	--	--	37-42	EH	--
31-36	VH	2.5	4.0	7.5	4.0	5.5	6.5	7.5	31-36	VH	600
25-30	HI	2.0	4.0	7.5	3.5	4.5	5.5	6.5	25-30	HI	1000
19-24	MH	2.0	4.5	7.5	3.0	4.0	5.0	6.0	19-24	MH	1600
13-18	ML	1.5	5.0	8.0	2.5	3.5	4.5	5.5	13-18	ML	2100
7-12	LO	1.5	5.0	7.5	2.0	3.0	4.0	5.0	7-12	LO	2400
1-6	VL	1.0	4.5	6.5	1.5	2.5	3.5	4.5	1-6	VL	2900

FIRE POWER CHART

Guns	Type Weapons	Ammo	Criticals
N1	2x 7.7mm MG	12	4
N2	2x 7.7mm MG	12	4
N3	1x 20mm HS402 cannon	3	2

GUN ATTACK FACTORS

Range	N1	N2	N3	Total
0	11	11	22	22/44
1	8	8	16	16/32
2	6	6	12	12/24
3	4	4	8	8/16
4	3	3	6	6/12
5	2	2	4	4/8
6	--	--	3	--/3
7	--	--	--	--

WEAPON STATION LOCATION

POWER VERSUS SPEED CHART

Levels	Bands	1.0 - 4.5	5.0 - 7.5	8.0 - 9.5	10.0+	Band
43+	UH	--	--	--	--	UH
37-42	EH	--	--	--	--	EH
31-36	VH	1	--	--	--	VH
25-30	HI	2	--	--	--	HI
19-24	MH	4	--	--	--	MH
13-18	ML	7	4	--	--	ML
7-12	LO	7	4	--	--	LO
1-6	VL	7	--	--	--	VL
Banking FPs		1	1	2	--	
Side Slip FPs		1	2	3	--	

NOTES AND VARIANTS

Avia B-534.IV: A well-built, streamlined biplane with an enclosed cockpit, this was one of the ultimate biplane fighters. It was fast, reliable - and obsolete. A B-534 came in a close 2nd to a Bf109B in the Zurich International Flying Meet in July 1937. About 250 in Czech service in March, 1939; 12 sold to Yugoslavia; 6 sold to Greece. Fixed gear. Use total to the left of the slash.

After Czechoslovakia was occupied, 3 squadrons (11th, 12th, 13th) of B-534s were part of the Slovakian Air Force. In July, 1941, these were sent to the Kiev sector of the Russian front. However, morale was low and their combat record undistinguished. 48 served in Bulgaria with home defense squadrons, opposing US B-24s on their way back from Ploesti.

Bk-534: Variant built with an HS-402 Hispano Suiza 20mm between the cylinder banks and firing through the spinner. Use right total. 35 built.

Avia B.135

A/C Type: Day Fighter
 Engine(s): Avia-built Hispano-Suiza 12 Ycrs
 Eng. Pwr: 790-860-hp, Liquid-cooled, NonF.I.
 A/C Crew: Pilot

Maximum Speed: 332 mph @ 9,800 ft
 Maximum Ceiling: 27,890 ft
 Defense factor: 5 Size Modifier: 0
 Damage Factor: 7/11 Endurance: 72
 Cockpit View: Fair Blind Area: Rear Low
 Protection: Engine +1 Fuel +0 Cockpit +0
 Climb Dece/ Dive Accel: 3.0 / 1.0
 Weight and Load Limit: 450 / 2-NA
Wpn Stations Weight Allowed Loads
 1 450 lbs 200 kg bomb

Country: Bulgaria

Service Entry Date: 1941

Class: F

Victory Points: 3-6

AIRCRAFT PERFORMANCE CHART

Altitude Levels	Bands	Minimum Speed	Maximum Speed	Maximum Dive Spd	Min TT(3)	Min HT(4)	Min BT(5)	Min ET(6)	Altitude Levels	Bands	Average Rate of Climb
43+	UH	--	--	--	--	--	--	--	43+	UH	--
37-42	EH	--	--	--	--	--	--	--	37-42	EH	--
31-36	VH	--	--	--	--	--	--	--	31-36	VH	--
25-30	HI	3.0	5.0	9.0	5.0	6.5	7.5	8.5	25-30	HI	1000
19-24	MH	2.5	5.5	9.5	4.5	6.0	7.0	8.0	19-24	MH	1600
13-18	ML	2.5	6.0	9.5	4.0	5.5	6.5	7.5	13-18	ML	2100
7-12	LO	2.0	6.5	9.5	3.5	4.5	5.5	6.5	7-12	LO	2400
1-6	VL	2.0	6.0	8.5	3.5	4.0	5.0	6.0	1-6	VL	2600

FIRE POWER CHART

Guns	Type Weapons	Ammo	Criticals
N1	2x 7.9mm Mk 30 mg	12	4
N2	1x 20mm Oerlikon FFS	4	2

GUN ATTACK FACTORS

Range	N1	N3	Total
0	11	18	29
1	8	12	20
2	6	8	14
3	4	6	10
4	3	4	7
5	2	3	5
6	--	2	2
7	--	--	--

WEAPON STATION LOCATION

1

POWER VERSUS SPEED CHART

Levels	Bands	1.0 - 4.5	5.0 - 7.5	8.0 - 9.5	10.0+	Band
43+	UH	--	--	--	--	UH
37-42	EH	--	--	--	--	EH
31-36	VH	--	--	--	--	VH
25-30	HI	2	1	--	--	HI
19-24	MH	4	1	--	--	MH
13-18	ML	5	2	--	--	ML
7-12	LO	6	3	--	--	LO
1-6	VL	6	3	--	--	VL
Banking FPs		2	3	5	7	
Side Slip FPs		2	4	6	8	

NOTES AND VARIANTS

Avia B.135: Developed by the Czechs in 1938 and completed after the German occupation. Shown at the Brussels Aeronautical Exhibition in the summer of 1939. 12 Ordered by Bulgaria, delivered in 1940. In 1941, the program was shut down to retool the factory for German aircraft. The Bulgarian fighters were used against USAAF bombers attacking Rumanian oilfields, a job they were more successful at than Bulgaria's PZL P.24s. One aircraft survived the war. Oerlikon FFS is the equivalent of the German 20mm FFM.