

Amiot Am.143M

Country: France

Service Entry Date: July, 1935

A/C Type: Long-Range Recon Bomber
 Engine(s): 2x G-R 14 Kirs/jrs Mistral Major
 Eng. Pwr: 1740-1800 hp, air-cooled
 A/C Crew: Pilot, Bombadier/Navigator,
 RadioOp/Gunner, 2 Gunners
 Maximum Speed: 193 mph at 13,100 ft
 Maximum Ceiling: 25,920 / 20,700 / 16,000 ft.
 Defense factor: 6 Size Modifier: +1
 Damage Factor: 11/17 Endurance: 290
 Cockpit View: Fair Blind Area: None

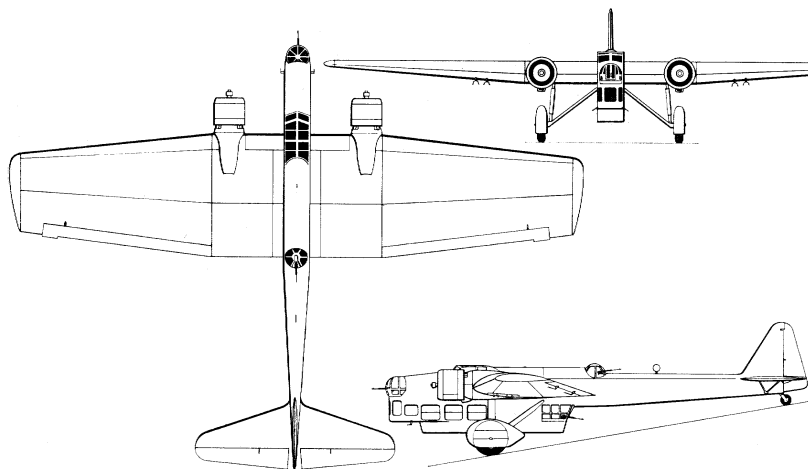

Protection: Cockpit +0 Fuel +0 Engine +0
 Climb Dece/ Dive Accel: 2.0 / 1.0
 Weight and Load Limit: 3600 / 10-18

Wpn Stations Weight Allowed Loads
 3 (bombbay) 1760 4x 100/200kg or
 16x50kg/64x10kg
 1,2,4,5 441 1x 100/200kg or
 5x 30kg flare

Class: M

Victory Points: 4-7

AIRCRAFT PERFORMANCE CHART

Altitude Levels	Bands	Minimum Speed	Maximum Speed	Maximum Dive Spd	Min TT(2)	Min HT(3)	Min BT(-)	Min ET(-)	Altitude Levels	Bands	Average Rate of Climb
43+	UH	--	--	--	--	--	--	--	43+	UH	--
37-42	EH	--	--	--	--	--	--	--	37-42	EH	--
31-36	VH	--	--	--	--	--	--	--	31-36	VH	--
25-30	HI	2.0	3.0	6.0	4.0	5.5	--	--	25-30	HI	200
19-24	MH	2.0	3.5	6.5	4.0	5.0	--	--	19-24	MH	400
13-18	ML	1.5	4.0	6.5	3.5	4.5	--	--	13-18	ML	600
7-12	LO	1.5	4.0	6.5	3.0	4.0	--	--	7-12	LO	900
1-6	VL	1.5	3.5	6.5	2.5	3.5	--	--	1-6	VL	900

FIRE POWER CHART

Guns	Type Weapons	Ammo	Criticals
FG1	1x 7.5mm Browning	13	4
FG2	1x 7.5mm Browning	10	4
DT	1x 7.5mm MAC34	20	4
VG	1x 7.5mm MAC34	20	4

GUN ATTACK FACTORS

Range	FG1	FG2	DT	VG
0	4	3	4	4
1	3	2	3	3
2	2	1	2	2
3	1	1	2	1
4	1	1	1	1
5	1	1	1	1
6	--	--	--	--
7	--	--	--	--

WEAPON STATION LOCATION

1,2 3 4,5

POWER VERSUS SPEED CHART

(per engine)

Levels	Bands	1.0 - 4.5	5.0 - 7.5	8.0 - 9.5	10.0+	Band
43+	UH	--	--	--	--	UH
37-42	EH	--	--	--	--	EH
31-36	VH	--	--	--	--	VH
25-30	HI	0.5	--	--	--	HI
19-24	MH	0.5	--	--	--	MH
13-18	ML	1.0	--	--	--	ML
7-12	LO	1.0	--	--	--	LO
1-6	VL	1.0	--	--	--	VL

Banking FPs	3	4	--	--
Side Slip FPs	4	5	--	--

NOTES AND VARIANTS

DEFENSIVE GUN ARCS

FG1: Fwd+60, All low to All high
 FG2: Fwd+30, All low to level
 DT: All around, Level to All high
 except: 12&6 lines All high
 VG: Rear+30, Level to All low

Amiot 143M: Long range recon bomber used for leaflets during the Sitzkrieg and then for night raids. 138 built.

Obsolete in September 1939, it equipped 6 groupes (about 60 aircraft); 4 groupes left by May 1940. 12 aircraft (1 flight from each groupe) called to daylight raid on the Sedan bridges - and badly shot up for their pains. Otherwise, in 197 sorties (mostly recon), only 4 were shot down. Post-Vichy survivors used as transports in North Africa.

Amiot Am.354 B4

Country: France

Service Entry Date: April, 1940

A/C Type: Medium Bomber
 Engine(s): 2x G-R 14N 48/49 14-cyl radials
 Eng. Pwr: 1920-2120-hp, air-cooled
 A/C Crew: Pilot, Bombadier/Navigator, RadioOp/Gunner, Gunner
 Maximum Speed: 298 mph at 13,120 ft
 Maximum Ceiling: 32,800 / 28,000 / 22,000 ft.
 Defense factor: 6 Size Modifier: +1
 Damage Factor: 11/17 Endurance: 429
 Cockpit View: Goodr Blind Area: None
 Protection: Cockpit +0 Fuel +0 Engine +0
 Climb Dece/ Dive Accel: 2.0 / 1.0
 Weight and Load Limit: 2600 / 6-10
 Wpn Stations Weight Allowed Loads
 1 (bombbay) 2600 2x 500kg bombsor
 6x 200kg bombs

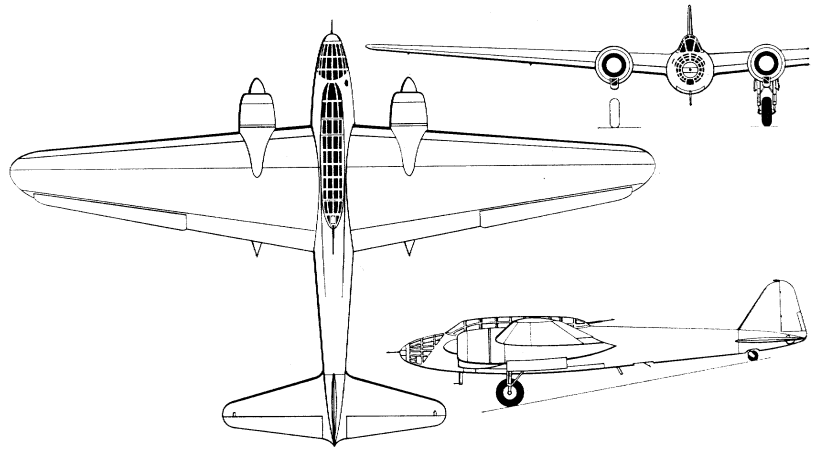

Class: M

Victory Points: 5-8

AIRCRAFT PERFORMANCE CHART

Altitude Levels	Bands	Minimum Speed	Maximum Speed	Maximum Dive Spd	Min TT(2)	Min HT(3)	Min BT(-)	Min ET(-)	Altitude Levels	Bands	Average Rate of Climb
43+	UH	--	--	--	--	--	--	--	43+	UH	--
37-42	EH	--	--	--	--	--	--	--	37-42	EH	--
31-36	VH	3.0	5.0	9.0	4.5	5.5	--	--	31-36	VH	400
25-30	HI	2.5	5.0	9.0	4.0	5.0	--	--	25-30	HI	600
19-24	MH	2.0	5.5	9.0	3.5	4.5	--	--	19-24	MH	900
13-18	ML	2.0	6.0	9.0	3.0	4.0	--	--	13-18	ML	1200
7-12	LO	2.0	5.5	8.5	2.5	3.5	--	--	7-12	LO	1500
1-6	VL	1.5	5.0	7.5	2.5	3.5	--	--	1-6	VL	1700

FIRE POWER CHART

Guns	Type Weapons	Ammo	Criticals
FG	1x 7.5mm MAC34	8	4
DT	1x 20mm HS404 cannon	6	2
VG	1x 7.5mm MAC34	13	4

GUN ATTACK FACTORS

Range	FG	DT	VG
0	3	14	3
1	2	10	2
2	1	6	1
3	1	4	1
4	1	3	1
5	1	2	1
6	--	1	--
7	--	--	--

WEAPON STATION LOCATION

POWER VERSUS SPEED CHART

(per engine)

Levels	Bands	1.0 - 4.5	5.0 - 7.5	8.0 - 9.5	10.0+	Band
43+	UH	--	--	--	--	UH
37-42	EH	--	--	--	--	EH
31-36	VH	0.5	0.5	--	--	VH
25-30	HI	1.0	0.5	--	--	HI
19-24	MH	1.5	0.5	--	--	MH
13-18	ML	2.5	1.5	--	--	ML
7-12	LO	2.5	1.5	--	--	LO
1-6	VL	2.5	1.5	--	--	VL
Banking FPs		3	4	6	8	
Side Slip FPs		4	5	7	10	

NOTES AND VARIANTS

DEFENSIVE GUN ARCS

FG: Front, Level
 DT: Rear, High
 VG: Rear, Level to Low

Amiot 354: A modern Medium bomber developed too late to help France. GB I/21 and II/21 were converting from MB.210s in May '40, with 6 Am.354s between them.

They kept converting as aircraft were available, flying the MB.210s on night operations. About 200 were waiting for some final parts (propellers, defensive guns, radios, and so on) during the invasion. 35 accepted, 13 lost May & June '40 - 3 to enemy action, 10 from training accidents. Four used as transports by the Luftwaffe, two with 1./KG200 (the special service geschwader). Others used for French air mail service. Engines taken by Germany for use with Me323.

Bloch MB.210 BN5

A/C Type: Medium Bomber
 Engine(s): 2 Gnome-Rhone 14N 10/11 radials
 Eng. Pwr: 2x 1140 hp, air-cooled, Non-F.I.
 A/C Crew: Pilot, Co-pilot, Radio op/gunner, Bombadier/observer, Gunner

Maximum Speed: 200 mph at 11,480 ft
 Maximum Ceiling: 32,480 ft./27,000/21,000

Defense factor: 6 Size Mod: +1
 Damage Factor: 11/16 Endurance: 194
 Cockpit View: Fair Blind Area: Rear low

Protection: Cockpit +0 Fuel +0 Engine +0

Climb Dece/ Dive Accel: 2.0 / 1.0

Weight and Load Limit: 3800 / 6-12

Wpn Stations	Weight	Allowed Loads
2 (bombbay)	3550	128x 10kg bombs or 32x 50kg bombs or 8x 200kg bombs or 2x 500kg bombs
1,3	132	2x 30kg Flares

Country: France

Service Entry Date: Dec, 1935

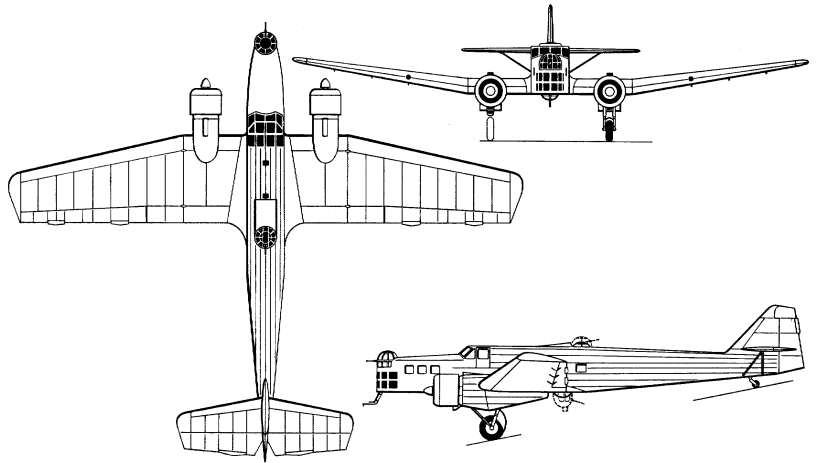

Class: M

Victory Points: 4-8

AIRCRAFT PERFORMANCE CHART

Altitude Levels	Bands	Minimum Speed	Maximum Speed	Maximum Dive Spd	Min TT(2)	Min HT(3)	Min BT(-)	Min ET(-)	Altitude Levels	Bands	Average Rate of Climb
43+	UH	--	--	--	--	--	--	--	43+	UH	--
37-42	EH	--	--	--	--	--	--	--	37-42	EH	--
31-36	VH	2.5	3.0	6.5	4.0	6.0	--	--	31-36	VH	200
25-30	HI	2.5	3.0	6.5	3.5	5.0	--	--	25-30	HI	400
19-24	MH	2.0	3.5	6.5	3.0	4.5	--	--	19-24	MH	600
13-18	ML	1.5	4.0	7.0	3.0	4.0	--	--	13-18	ML	800
7-12	LO	1.5	4.0	6.5	2.5	3.5	--	--	7-12	LO	1,000
1-6	VL	1.5	3.5	5.5	2.5	3.5	--	--	1-6	VL	1,000

FIRE POWER CHART

Guns	Type Weapons	Ammo	Criticals
FT	1x 7.5mm MAC34	13	4
DT	1x 7.5mm MAC34	13	4
VT	1x 7.5mm MAC34	13	4

GUN ATTACK FACTORS

Range	FT	DT	VT
0	3	4	3
1	2	3	2
2	1	2	1
3	1	1	1
4	1	1	1
5	1	1	1
6	-	--	-
7	-	--	-

WEAPON STATION LOCATION

1 2 3

POWER VERSUS SPEED CHART

(per engine)		1.0 - 4.5	5.0 - 7.5	8.0 - 9.5	10.0+	Band
Levels	Bands					
43+	UH	--	--	--	--	UH
37-42	EH	--	--	--	--	EH
31-36	VH	0.5	--	--	--	VH
25-30	HI	1.0	--	--	--	HI
19-24	MH	1.5	--	--	--	MH
13-18	ML	2.0	--	--	--	ML
7-12	LO	2.0	--	--	--	LO
1-6	VL	2.0	--	--	--	VL
Banking FPs		3	4	6	8	
Side Slip FPs		3	5	7	10	

NOTES AND VARIANTS

DEFENSIVE GUN ARCS

FT: Front+30, Level to High
 DT: Level, High, All
 VT: Rear+30, Low

MB.200: Available 1934. Earlier version of 210. Older engine, less aerodynamic, smaller bombload. Power -.5/eng; Max level speed -.5; Max Dive Speed -1; bombload = 2650 lbs.

In Sept '39, it still equipped 4 groupes in France and 3 overseas. 124 served with Czech air force '36-38. Fixed gear.

MB.210B.5: Replacement for the MB.200, it was being phased out of active service between September 1939 and May 1940, equipping 12 Groupes in September and 5 in May. 24 served with Rumania; 35 with Republican Spain. Retractable turrets.

Liore & Olivier LeO 451 B4

A/C Type: Medium Bomber
 Engine(s): 2 Gnome-Rhone 14N 48/49 radial
 Eng. Pwr: 2x 1140 hp, air-cooled, Non-F.I.
 A/C Crew: Pilot, radio operator, 2 Gunners

Maximum Speed: 307 mph at 15,000 ft
 Maximum Ceiling: 29,500 ft./22,000/19,000

Defense factor: 5 Size Mod: +1
 Damage Factor: 13/20 Endurance: 420
 Cockpit View: Fair Blind Area: Rear,low

Protection: Cockpit +0 Fuel +0 Engine +0

Climb Dece/ Dive Accel: 2.0 / 1.0

Weight and Load Limit: 4400 / 10-16

Wpn Stations	Weight	Allowed Loads
1, 3 (bombbay)	660	3x 100 kg bombs
2 (bombbay)	3080	14x 100 kg bomb

Country: France

Service Entry Date: August, 1939

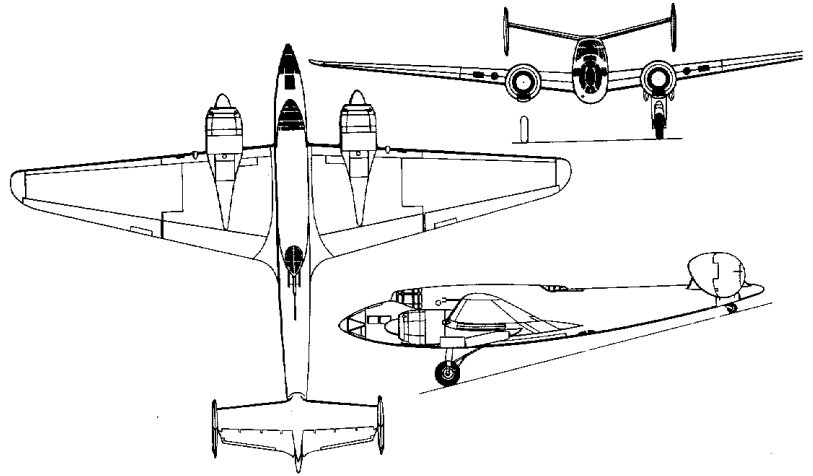

Class: M

Victory Points: 8-16

AIRCRAFT PERFORMANCE CHART

Altitude Levels	Bands	Minimum Speed	Maximum Speed	Maximum Dive Spd	Min TT(2)	Min HT(3)	Min BT(4)	Min ET(5)	Altitude Levels	Bands	Average Rate of Climb
43+	UH	--	--	--	--	--	--	--	43+	UH	--
37-42	EH	--	--	--	--	--	--	--	37-42	EH	--
31-36	VH	--	--	--	--	--	--	--	31-36	VH	--
25-30	HI	3.0	4.5	8.0	4.5	6.0	7.0	--	25-30	HI	600
19-24	MH	2.5	5.0	8.5	4.0	5.5	6.5	--	19-24	MH	900
13-18	ML	2.5	5.5	8.5	3.5	5.0	6.0	8.0	13-18	ML	1200
7-12	LO	2.0	5.5	8.5	3.0	4.5	5.5	7.0	7-12	LO	1500
1-6	VL	2.0	5.0	8.0	3.0	4.0	5.0	6.5	1-6	VL	1800

FIRE POWER CHART

Guns Type	Weapons	Ammo	Criticals
N1	1x 7.5mm MAC34	mg 9	4
DT	1x 20mm HS 404	5	2
VG	1x 7.5mm MAC34	mg 3x3	4

GUN ATTACK FACTORS

Range	N1	VG	DT
0	6	3	14
1	4	2	10
2	3	2	6
3	2	1	4
4	1	1	3
5	1	1	2
6	-	--	1
7	-	--	--

WEAPON STATION LOCATION

1 2 3

POWER VERSUS SPEED CHART

(per engine)

Levels	Bands	1.0 - 4.5	5.0 - 7.5	8.0 - 9.5	10.0+	Band
43+	UH	--	--	--	--	UH
37-42	EH	--	--	--	--	EH
31-36	VH	--	--	--	--	VH
25-30	HI	1.0	--	--	--	HI
19-24	MH	1.5	.5	--	--	MH
13-18	ML	2.0	1.0	--	--	ML
7-12	LO	2.5	1.5	--	--	LO
1-6	VL	2.5	1.5	--	--	VL
Banking FPs		2	3	5	6	
Side Slip FPs		3	4	6	7	

NOTES AND VARIANTS

DEFENSIVE GUN ARCS

DT: Rear, Level to High
 VG: Rear, Low

LeO 451 B4: 192 available by May, 1940, arming 8 groups. By most accounts, an excellent aircraft, though a bit short on defensive armament. Used badly for ground attack in small numbers without escort. Later used by Vichy in North Africa and Syria.

Farman F.222.2 BN5

Country: France

Service Entry Date: 1936

A/C Type: Heavy Night Bomber
 Engine(s): 4x Gnome-Rhone 14N 11/15 radial
 Eng. Pwr: 4x 950-1050-hp, air-cooled, Non-FI
 A/C Crew: Pilot, Co-Pilot, Radio/Gunner, Bombadier, Gunner

Maximum Speed: 224 mph at 13,100 ft
 Maximum Ceiling: 26,250 ft./22,00/18,000

Defense factor: 7 Size Modifier: +1
 Damage Factor: 14/21 Endurance: 300
 Cockpit View: Fair Blind Area: None

Protection: Cockpit +0 Fuel +0 Engine +0
 Climb Dece/ Dive Accel: 2.0 / 1.0
 Weight and Load Limit: 8,580 / 12-20

Wpn Stations	Weight	Allowed Loads
1 (bombbay)	8580	15 bombs up to 500 kg

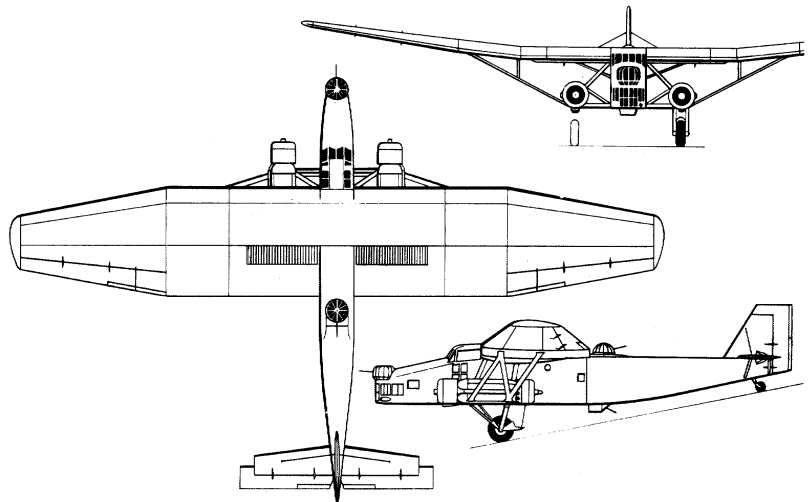

Class: H

Victory Points: 6-12

AIRCRAFT PERFORMANCE CHART

Altitude Levels	Bands	Minimum Speed	Maximum Speed	Maximum Dive Spd	Min TT(2)	Min HT(3)	Min BT(-)	Min ET(-)	Altitude Levels	Bands	Average Rate of Climb
43+	UH	--	--	--	--	--	--	--	43+	UH	--
37-42	EH	--	--	--	--	--	--	--	37-42	EH	--
31-36	VH	--	--	--	--	--	--	--	31-36	VH	--
25-30	HI	3.0	4.0	7.5	4.5	6.0	7.0	--	25-30	HI	100
19-24	MH	2.5	4.0	7.0	4.0	5.5	6.5	--	19-24	MH	300
13-18	ML	2.5	4.5	7.0	3.5	5.0	6.0	--	13-18	ML	700
7-12	LO	2.0	4.5	7.0	3.0	4.5	5.5	--	7-12	LO	1100
1-6	VL	2.0	4.0	6.5	3.0	4.0	5.0	--	1-6	VL	1400

FIRE POWER CHART

Guns	Type Weapons	Ammo	Criticals
FG	1x 7.5mm MAC34	3x3	4
DT	1x 7.5mm MAC34	3x3	4
VG	1x 7.5mm MAC34	3x3	4

GUN ATTACK FACTORS

Range	FG	DT	VG
0	4	4	4
1	3	3	3
2	2	2	2
3	1	1	1
4	1	1	1
5	1	1	1
6	--	--	--
7	--	--	--

WEAPON STATION LOCATION

POWER VERSUS SPEED CHART

(per engine)

Levels	Bands	1.0 - 4.5	5.0 - 7.5	8.0 - 9.5	10.0+	Band
43+	UH	--	--	--	--	UH
37-42	EH	--	--	--	--	EH
31-36	VH	--	--	--	--	VH
25-30	HI	0.5	--	--	--	HI
19-24	MH	0.5	--	--	--	MH
13-18	ML	1.0	--	--	--	ML
7-12	LO	1.5	--	--	--	LO
1-6	VL	1.5	--	--	--	VL
Banking FPs		3	4	--	--	
Side Slip FPs		4	5	--	--	

NOTES AND VARIANTS

DEFENSIVE GUN ARCS

FG: front, Level

DT: Rear, High

VG: Rear+30, Level to Low (Dustbin)

Dustbin: Gun position lowered from ac, facing aft. 1 turn to lower, 2 to raise, 1 decel while lowered

Farman 222.2 BN5: Ugly, unmaneuverable, and slow, this was typical of France's pre-modernization air force of the mid-30s. This "advanced" version had retractable gear, but showed little improvement over its predecessor. It did have long range and carried a large bomb load. In the opening months of the war, Farman 222s made a leaflet raids over Germany - including at least one over Berlin - later changing to bombing missions. Only one was lost during the Battle of France - and that was a flying accident. Vichy and the Luftwaffe used them as transports through 1944. 24 built.. 4 used in Indochina.

Farman F.223.3 BN5

Country: France

Service Entry Date: 1939

A/C Type: Heavy Bomber
 Engine(s): 4 Hispano-Suiza 12Y 29 inline
 Eng. Pwr: 4x910 hp, liquid-cooled, Non-F.I.
 A/C Crew: Pilot, Co-pilot, Bombadier/Nav
 RadioOp/Gunner, Gunner
 Maximum Speed: 273 mph at 15,000 ft
 Maximum Ceiling: 26,300 ft./22,000 ft/19,000 ft
 Defense factor: 7 Size Mod: +2
 Damage Factor: 15/22 Endurance: 512
 Cockpit View: Fair Blind Area: Rear,low

Protection: Cockpit +0 Fuel +0 Engine +0
 Climb Dece/ Dive Accel: 2.0 / 1.0
 Weight and Load Limit: 9240 / 12-20

Wpn Stations	Weight	Allowed Loads
1 (bombbay)	2310	Bombs
2 (bombbay)	2310	
3 (bombbay)	2310	
4 (bombbay)	2310	

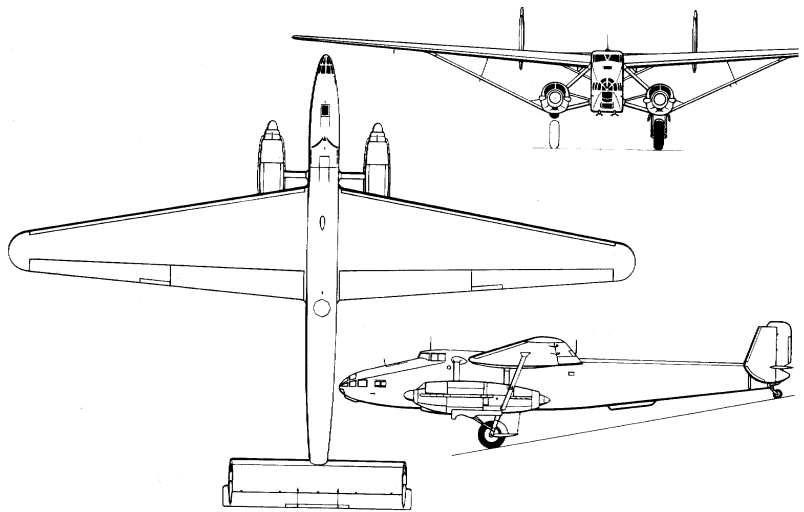

Class: H

Victory Points: 5-10

AIRCRAFT PERFORMANCE CHART

Altitude Levels	Bands	Minimum Speed	Maximum Speed	Maximum Dive Spd	Min TT(2)	Min HT(3)	Min BT(4)	Min ET(5)	Altitude Levels	Bands	Average Rate of Climb
43+	UH	--	--	--	--	--	--	--	43+	UH	--
37-42	EH	--	--	--	--	--	--	--	37-42	EH	--
31-36	VH	--	--	--	--	--	--	--	31-36	VH	--
25-30	HI	3.0	4.0	7.5	3.5	4.5	--	--	25-30	HI	300
19-24	MH	2.5	4.5	7.5	3.5	4.0	--	--	19-24	MH	700
13-18	ML	2.5	5.0	8.0	3.0	4.0	--	--	13-18	ML	1,000
7-12	LO	2.0	4.5	7.0	3.0	3.5	--	--	7-12	LO	1,300
1-6	VL	2.0	4.0	6.0	2.5	3.5	--	--	1-6	VL	1,300

FIRE POWER CHART

Guns	Type Weapons	Ammo	Criticals
FG	1x 7.5mm MAC34	3x3	4
DT	1x 20mm HS 404 cannon	3x3	2
VT	1x20mm HS 404 cannon	3x3	2

GUN ATTACK FACTORS

Range	FG	DG	VG
0	4	14	12
1	3	10	8
2	2	6	6
3	1	4	4
4	1	3	3
5	1	2	2
6	-	1	1
7	-	--	--

WEAPON STATION LOCATION

1,2,3,4

POWER VERSUS SPEED CHART

(per engine)

Levels	Bands	1.0 - 4.5	5.0 - 7.5	8.0 - 9.5	10.0+	Band
43+	UH	--	--	--	--	UH
37-42	EH	--	--	--	--	EH
31-36	VH	--	--	--	--	VH
25-30	HI	0.5	--	--	--	HI
19-24	MH	0.5	--	--	--	MH
13-18	ML	1.0	0.5	--	--	ML
7-12	LO	1.5	--	--	--	LO
1-6	VL	1.5	--	--	--	VL
Banking FPs		3	4	--	--	
Side Slip FPs		3	5	--	--	

NOTES AND VARIANTS

DEFENSIVE GUN ARCS

FG: Front, Level
 DG: Rear, High
 VG: Rear, Low

F.221s, F.222s and F.223.3s served together in GB15. Three F.223.4 (civilian longrange mail planes) were taken into naval service.

Farman F.223.3: Available 1939. Updated, more aerodynamic version of the F.222. 4 bombbays. 8 built. Used as transports by Vichy and Luftwaffe post 1940.